

ALERT SERVICE BULLETIN

Checking of the correct positioning of sealing plug in ignition housing for ROTAX® Engine Type 912 i (Series)

ATA System: 24-20-00 Internal generator

MANDATORY

1) Planning information

To obtain satisfactory results, procedures specified in this publication must be accomplished with accepted methods in accordance with prevailing legal regulations.

BRP-Rotax GmbH & Co KG cannot accept any responsibility for the quality of work performed in accomplishing the requirements of this publication.

1.1) Applicability

All versions of ROTAX® engine types 912 iSc Sport are affected, if at least one of the following criteria applies:

Criterion A) Engine serial number:

All engines of type:

Engine type	Serial number
912 iSc Sport	from S/N 4 417 413 up to S/N 4 417 424 inclusive

Criterion B) Parts set stator 912 iSc Sport part no. 481370:

Stator assy.	Serial number
Part no. 685062	from S/N 16.0540 up to S/N 16.0543 inclusive from S/N 16.0548 up to S/N 16.0549 inclusive from S/N 16.0552 up to S/N 16.0555 inclusive

Criterion C) Spare parts:

Further all engines are affected, which have been equipped with ignition housing with the part no. 611594 during engine repair, maintenance, general overhaul or any other exchange action before June 01, 2016 (delivery note).

NOTE: The ignition housing assy. may have been removed from the initial engine and used on another one.

For relevant information, see maintenance records and/or the log book.

1.2) Concurrent ASB/SB/SI and SL

None.

1.3) Reason

Field observation has shown that in isolated cases the sealing plug (see Fig. 1) was not pressed to its correct seating position in the ignition housing. In rare cases this may lead to loss of oil and subsequently loss of lubrication which leads to engine stoppage.

ALERT SERVICE BULLETIN

1.4) Subject

Checking of the correct positioning of sealing plug in ignition housing for ROTAX® engine type 912 i (Series).

1.5) Compliance

- Before the next flight
- Immediately, on undelivered engines / spare parts
- Before the initial installation of engine and/or spare part

but at the latest by 31. December 2017 the “Checking and if necessary re-setting of the sealing plug in ignition housing“ must be conducted according to the following instructions in section 3.



Non-compliance with these instructions could result in engine damages, personal injuries or death.

1.6) Approval

The technical content of this document is approved under the authority of DOA ref. EASA.21J.048.

1.7) Labor time

Estimated labor hours:

Engine installed in the aircraft: - - - labor time will depend on airframe installation and therefore no estimate is available from the engine manufacturer.

1.8) Mass data

change of weight: - - - none.

moment of inertia: - - - unaffected.

1.9) Electrical load data

No change.

1.10) Software modifications

No change.

1.11) References

In addition to this technical information refer to current issue of

- Illustrated Parts Catalog (IPC)
- Installation Manual (IM)
- Maintenance Manual Heavy (MMH)

NOTE: The status of the Manuals can be determined by checking the table of amendments. The 1st column of this table shows the revision status. Compare this number to that listed on the ROTAX website: www.FLYROTAX.com. Updates and current revisions can be downloaded for free.

1.12) Other Publications affected

None.

1.13) Interchangeability of parts

- All parts are interchangeable

d06442.fm

ALERT SERVICE BULLETIN

2) Material Information

2.1) Material- cost and availability

Price and availability will be provided on request by ROTAX® Authorized Distributors or their independent Service Centers.

2.2) Company support information

None.

2.3) Material requirement per engine

None.

2.4) Material requirement per spare part

None.

2.5) Rework of parts

None.

2.6) Special tooling/lubricant-/adhesives-/sealing compound/price and availability

Price and availability will be supplied on request by ROTAX® Authorized Distributors or their independent Service Centers:

Description	Qty/ engine	Part no.	Application
Insertion jig	1	676255	Sealing plug in ignition housing

NOTICE

If using these special tools observe the manufacturers specifications.

d06442.fm

ALERT SERVICE BULLETIN

3) Accomplishment/Instructions

- ROTAX® reserves the right to make any amendments to existing documents, which might become necessary due to this standardization, at the time of next revision or issue.

NOTE: Before maintenance, review the entire documentation to make sure you have a complete understanding of the procedure and requirements.

Accomplishment

All measures must be implemented and confirmed by at least one of the following persons or organizations:

- ROTAX® - Authorized Distributors or their independent Service Centers
- Persons with approved qualifications for the corresponding engine types. Only authorized persons (relevant iRMT Level) are entitled to carry out this work.

NOTE: All work has to be performed in accordance with the relevant Maintenance Manual.

Safety notice



Identifies an instruction which, if not followed, may cause serious injury or even fatal injury.



Identifies an instruction which, if not followed, may cause minor or moderate injury.



Identifies an instruction which, if not followed, may severely damage the engine or could void any warranty.

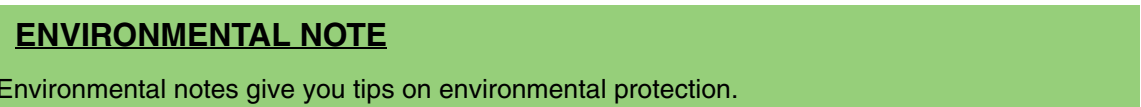

Environmental notes give you tips on environmental protection.

NOTE: Indicates supplementary information which may be needed to fully complete or understand an instruction.

3.1) Check the specified position of sealing plug



Following steps are important, read them carefully!

See Fig. 2.

Step	Procedure
1	Check the position of sealing plug in the relevant area of ignition housing assy. See Fig. 2.
2	The sealing plug must show to have been pressed in until the top of the ball is below the edge of the sleeve. See position OK in Fig. 2.
3	If you notice sealing plug position is OK, then there is no need for further procedures. NOTE: If you notice sealing plug position is NOT OK, then see section 3.2.

d06442.fm

ALERT SERVICE BULLETIN

3.2) Correcting sealing plug position (required if position of sealing plug is incorrect, see Fig. 2)

Step	Procedure
1	<p>Correct the sealing plug position with a hammer (max. 300 g / 0.66 lbs) and the relevant insertion jig part no. 676255 as per section 2.6. Intuitively control your manual insertion force just to set the ball in correct position. See Fig. 3.</p> <p>NOTE: The bore must be free of oil, grease and chips.</p> <p>NOTE: Make sure to insert the insertion jig in correct alignment of the center bore / center line of the sealing plug.</p>

NOTICE At application of the insertion jig make sure not to damage surface of the engine suspension frame etc.

ENVIRONMENTAL NOTE

All operating materials/fluids and cleaning products endanger the environment by improper disposal. Please observe the disposal regulations applicable in your country.

- Restore aircraft to the original operating configuration
- Connect negative terminal of the aircraft battery.

3.3) Test run

Conduct test run including leakage test. See chapter 12-20-00 of the latest Maintenance Manual Line for the respective engine type.

3.4) Summary

These instructions (section 3) have to be followed in accordance with the deadlines specified in section 1.5.

The execution of the mandatory Alert Service Bulletin must be confirmed in the log book.

I A revision bar outside of the page margin indicates a change to text or graphic.

Translation into other languages might be performed in the course of language localization but does not lie within ROTAX® scope of responsibility.

In any case the original text in English language and the metric units are authoritative.

3.5) Inquiries

Inquiries regarding this Alert Service Bulletin should be sent to the ROTAX® Authorized Distributor of your area.

A list of all ROTAX® Authorized Distributors or their independent Service Centers is provided on www.FLYROTAX.com.

d06442.fm

ALERT SERVICE BULLETIN

4) Appendix

The following drawings should convey additional information:

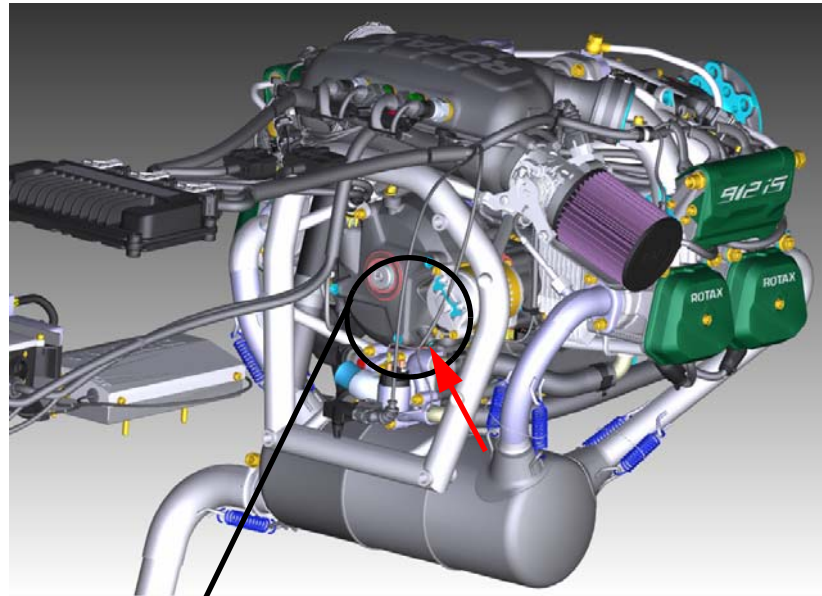

Detail A

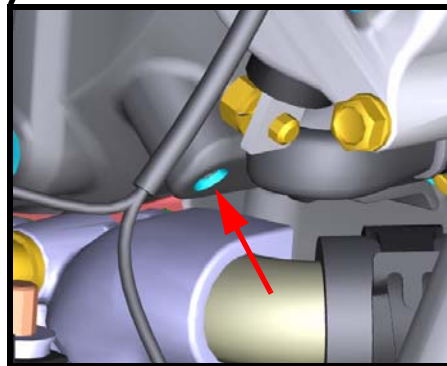
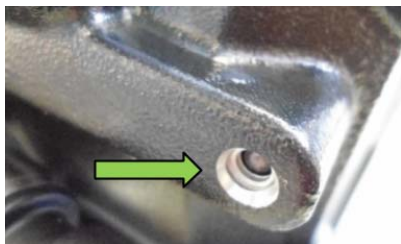

Fig. 1
Sealing plug in ignition housing

10272,10273

ALERT SERVICE BULLETIN



Sealing plug position "OK"



Sealing plug position "NOT OK"

Fig. 2
Good/bad comparison of sealing plug position

10275,10274

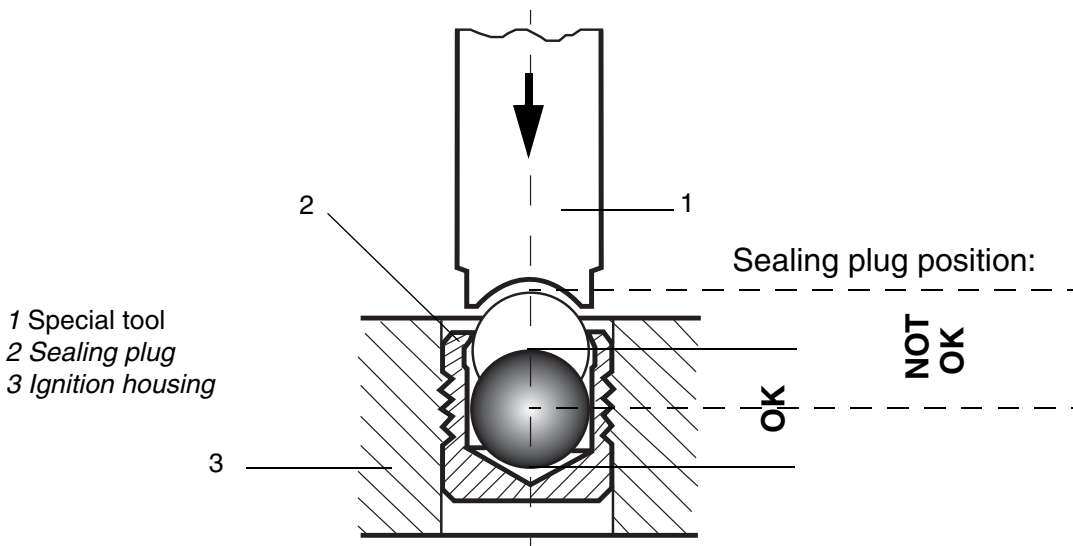

Fig. 3
Correcting the sealing plug position with special tool (insertion jig)

10276

NOTE:

The illustrations in this document show the typical construction. They may not represent full detail or the exact shape of the parts which have the same or similar function.

Exploded views are **not technical drawings** and are for reference only. For specific detail, refer to the current documents of the respective engine type.

d06442.fm